

RECTIFICATION OF LEAKED CONCRETE OVERHEAD TANKS (WATER GUARD 3020 N)



Summary

STEP 1: Assessment of Over Head tanks.

STEP 2: Crack filling and making of internal chamfers. (If needed).

STEP 3: Plugging internal pipe points. (If needed).

STEP 4: Internal Plastering (If needed).

STEP 5: Application of **Water Guard 3020N**.

STEP 6: Flood Test.

Detailed Description

Leaked overhead tanks can cause serious problems for the day to day functioning and usage of a structure. There can be many reasons for the leakage of overhead concrete tanks.

In the following description we will be tackling mainly with crack repairing of the internal concrete tank, plugging of pipe inlets and outlets, and correcting and making internal chamfers of the overhead tanks.

Step 1: Assessment of overhead tanks

It is essential to have a proper survey & diagnose the area where the water tank is being leaked & then move towards the rectification of the tank. The survey should be done both externally & internally within the overhead tank. It is to be ensured that the overhead tank is dry prior to the internal inspection so that any areas of the leakage can be identified easily.

During the inspection cracks within the overhead tank, leakage from the pipe inlets and outlets, and the condition of the chamfers along with the condition of the internal plaster need to be diagnosed thoroughly. Once the diagnosis of the problems has been done, working towards the rectifications of these problems can be done.

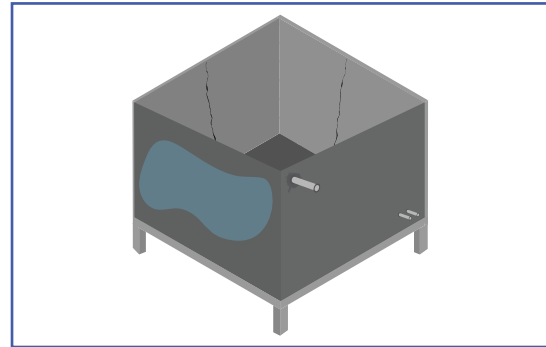

Step 2: Crack Filling & making of internal chamfers (If Needed)

Upon inspection if cracks are found over the plastered surface of the internal or external surface of the overhead tank, they should be further inspected for plaster hollow sounds, if the plaster has been de-bonded and there are hollow sounds, there will be a need for replastering. If there are no hollow sounds and the plaster is in a solid state, there may be a simple need for crack filling.

There is a wide range of Crack Fillers in the **Crack Heal Range** of Ressichem crack fillers. In general, if there are minor hairline cracks, **Crack Heal 920 2K** should be used, if the cracks are wide & need a deeper filling, **Ressi EPO Crack Fill** can also be used depending on the situation. For further guidance for the right selection of crack fillers please consult Ressichem representative.

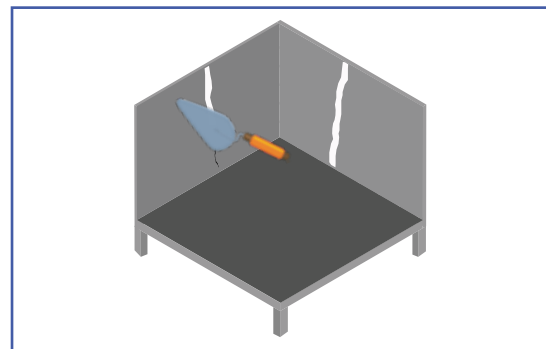

RECTIFICATION OF LEAKED CONCRETE OVERHEAD TANKS (WATER GUARD 3020 N)



If there are running cracks on both sides of the overhead tank and the structure of the retaining walls and base have been detached, please consult a structural engineer prior to any treatment over the overhead tank.

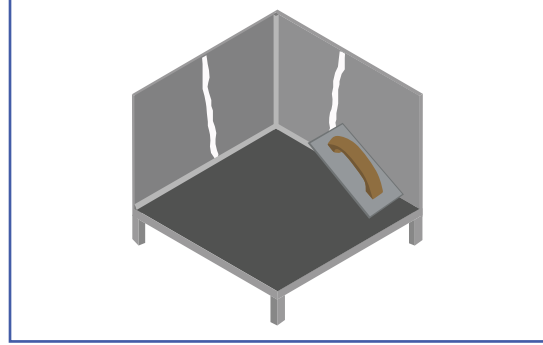

Step 3: Plugging internal pipe points. (If needed)

If on inspection it is found that the pipe inlets and outlets of the tanks have been leaking it is essential to plug those points of the pipes. A suitable crystalline plugging material can be used for this application. **Water Guard Crysta Coat 101** is a crystalline waterproofing material which can also be used as a plugging material for the pipe inlets and outlets of the tank. The pipe points through which the leakage is taking place can be cut open at 8mm and the **Water Guard Crysta Coat 101** mortar can be used to plug the points and seal them off. Once the points have been sealed, the points should be kept moist by damp curing for a period of minimum 4 days. Once after curing the plugging point of **Water Guard Crysta Coat 101** becomes dry. It should be coated over with **Water Guard 3020 N** so that there is proper bonding between the pipe & the crystalline plugging material. The same treatment can also be repeated from the exterior side of the overhead tank.

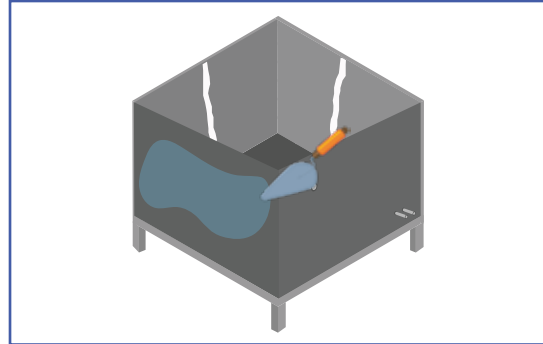

Step 4: Internal Plastering (If needed)

As mentioned previously, if there are hollow sounds within the plaster of the overhead tank, the entire area should be replastered. Replastering works can be done either with the use of **Patch 365 Plus** (Please refer to product datasheet for further information) or by adding **Ressi SBR 5850 & Silmix** in the cement and sand mix.

Using **Silmix** and **Ressi SBR 5850** as mortar admixtures ensures that there are no cracks in the plaster it is water repellent. It is recommended to add 1 Liter of **Silmix** along with 1 Ltr of **Ressi SBR 5850** with every bag of cement used for the plastering of internal & external areas of the overhead tank. It is to be ensured that the internal plaster of the overhead tank should be finished slightly rough, exposing some grains using a foam (Foam finish plaster). This will provide a good key for the subsequent coating of **Water Guard 3020 N**.

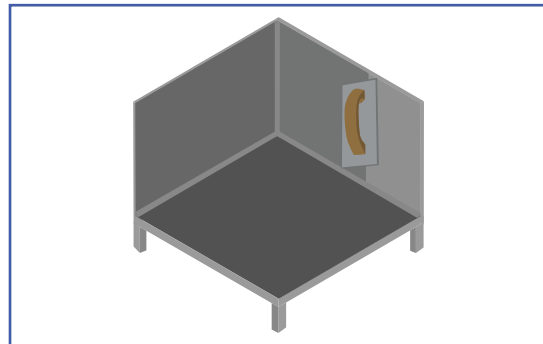

RECTIFICATION OF LEAKED CONCRETE OVERHEAD TANKS (WATER GUARD 3020 N)



Step 5: Application of Water Guard 3020N

Water Guard 3020N is a one component, acrylic co-polymer based flexible waterproofing system ideal for use on cementitious and metal surfaces. **Water Guard 3020N** should be applied on all internal sides of the overhead tank including the base areas and the walls along with the chamfers. The application of **Water Guard 3020N** is recommended in at least 2 coats of application. Both the coats should be applied in opposite right-angled directions. If the first coat is applied as a top to bottom pattern the second coat is to be applied in a left to right pattern.

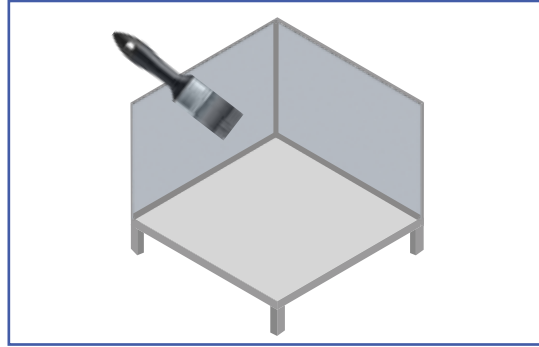

Step 6: Flood Test and usage of tank

Once the coating of **Water Guard 3020 N** has been completed, the overhead tank can be filled with water. In case there are still some leak points within the tank, they should be rectified accordingly. If all the diagnosis and application works have been conducted properly, there should not be any leakages in the overhead tank.

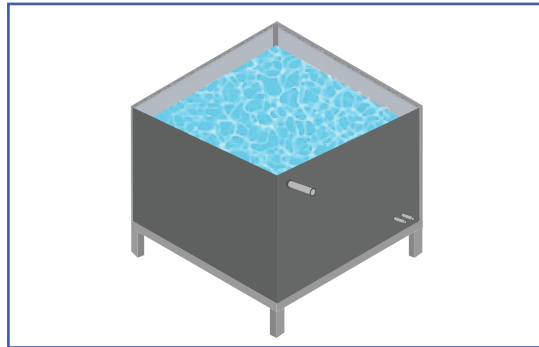

What is a Chamfer?

Is a transitional edge between two faces of an object. Sometimes defined as a form of bevel, it is often created at a 45° angle between two adjoining right-angled faces. (Wikipedia).

In waterproofing systems, making a **chamfer** is of great significance. Water normally gets stuck in areas which have sharp corners of 90° & on several occasions the leakage of water occurs from this the sharp angle of the water retaining bodies or areas where significant waterproofing is required. To minimize the effect of this, a **chamfer** is usually created to make sure that there are no sharp angles in the structure to minimize the effect of water coming in & out of the structure.

