



# Waterproofing system for Over Head tanks

Chemical Storage

**RESSICHEM**  
adding life and value to your property

# Step 1

Pouring of the concrete with the addition of **Max Flo Integra 4 (Powder)**

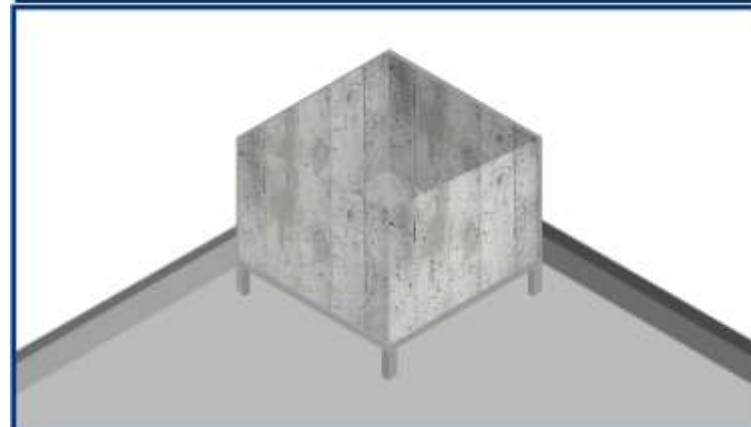
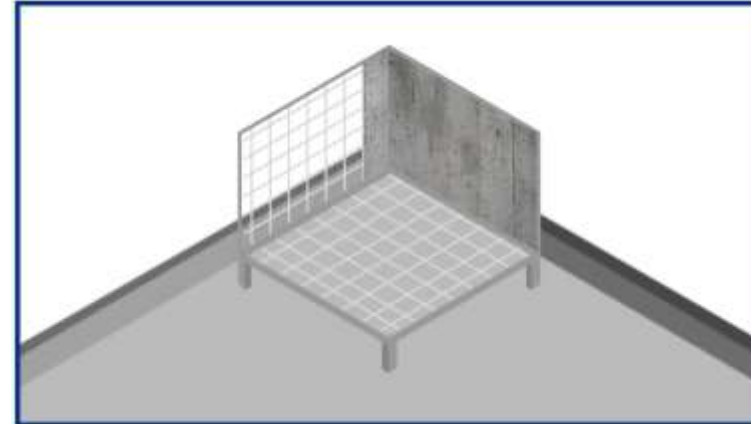
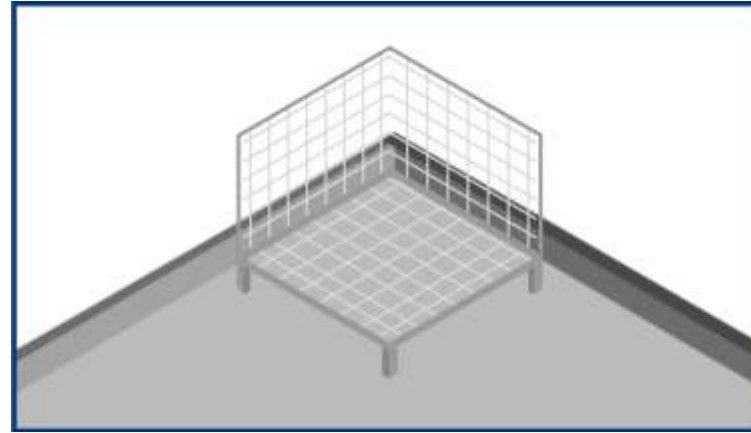

**MAX FLO**  
**INTEGRA 4 (POWDER)**  
PLASTICIZING INTEGRAL WATERPROOFING POWDER ADMIXTURE

**RESSICHEM**  
adding life and value to your property

## Step 2

Filling and Repairing of the concrete voids with the addition of **Ressi SBR 5850** in the cement sand repairing material.



## Step 3

Application of **Water Guard Crysta Coat 101** over the prepared concrete surface (internally and externally)

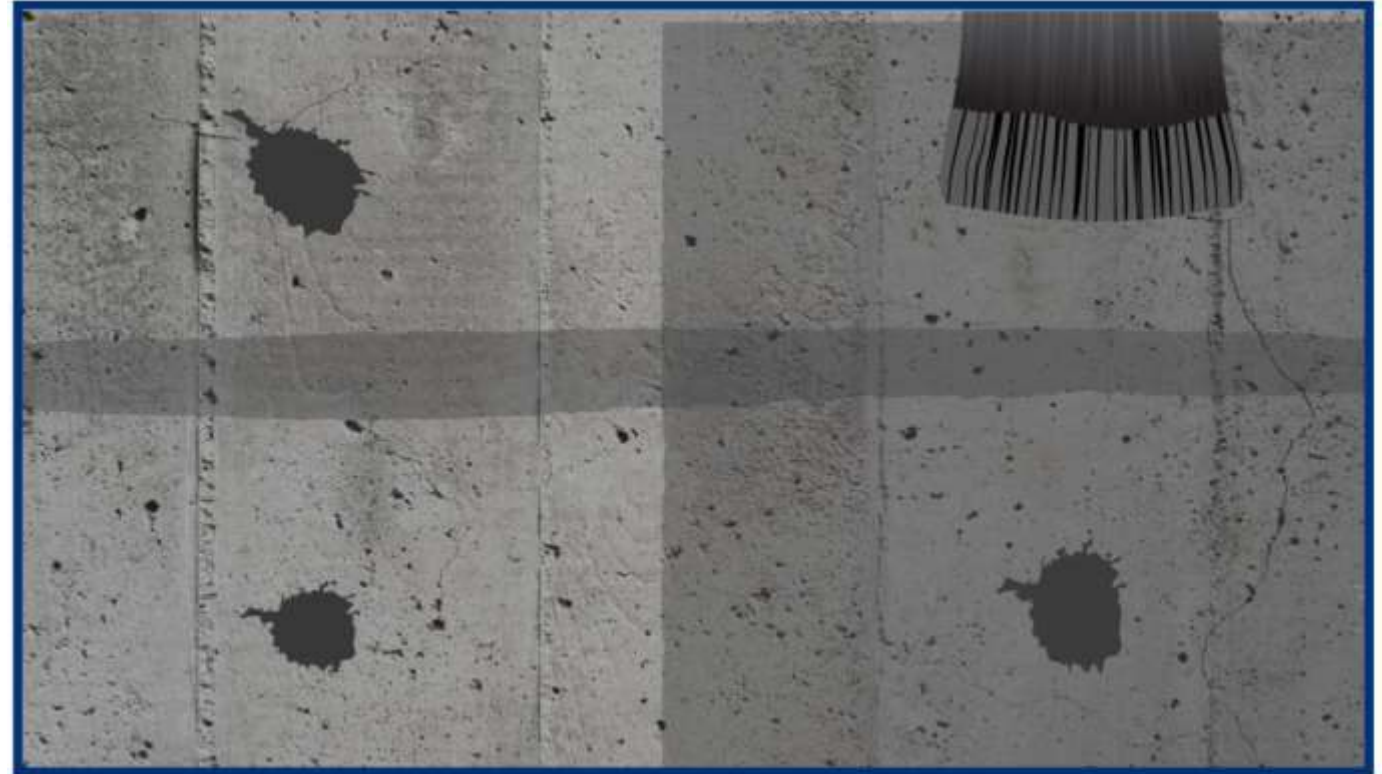

Note: 2 coats to be applied in opposite directions



**RESSICHEM**  
adding life and value to your property

## Step 4

Making of internal chamfers with the addition of **Ressi SBR 5850** and **Silmix** in the mortar used to make the chamfers and coating them over with **Water Guard Crysta Coat 101**

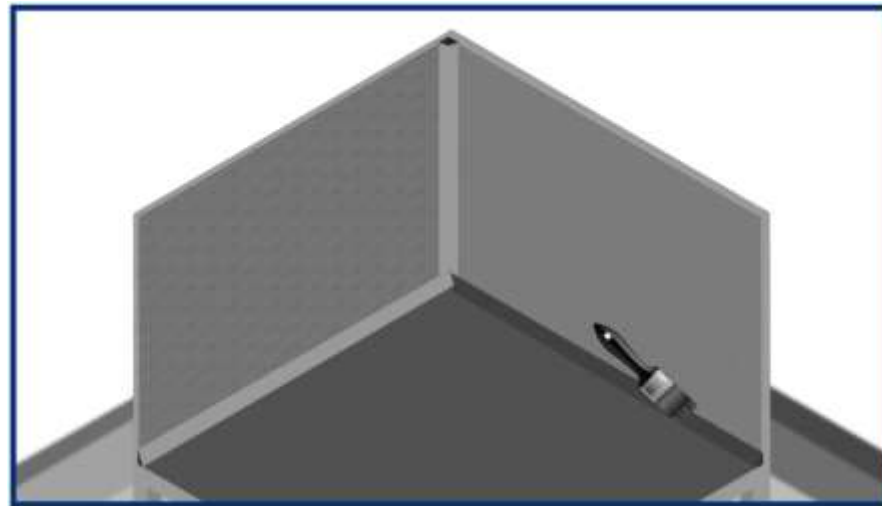
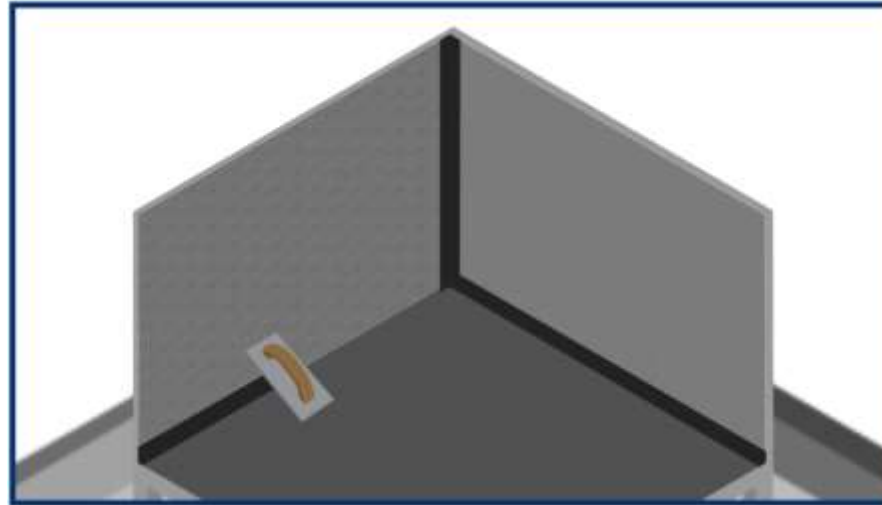

# Flood Test

Once chamfer and coating works have been completed it is recommended that a flood test is conducted prior to plastering and finishing

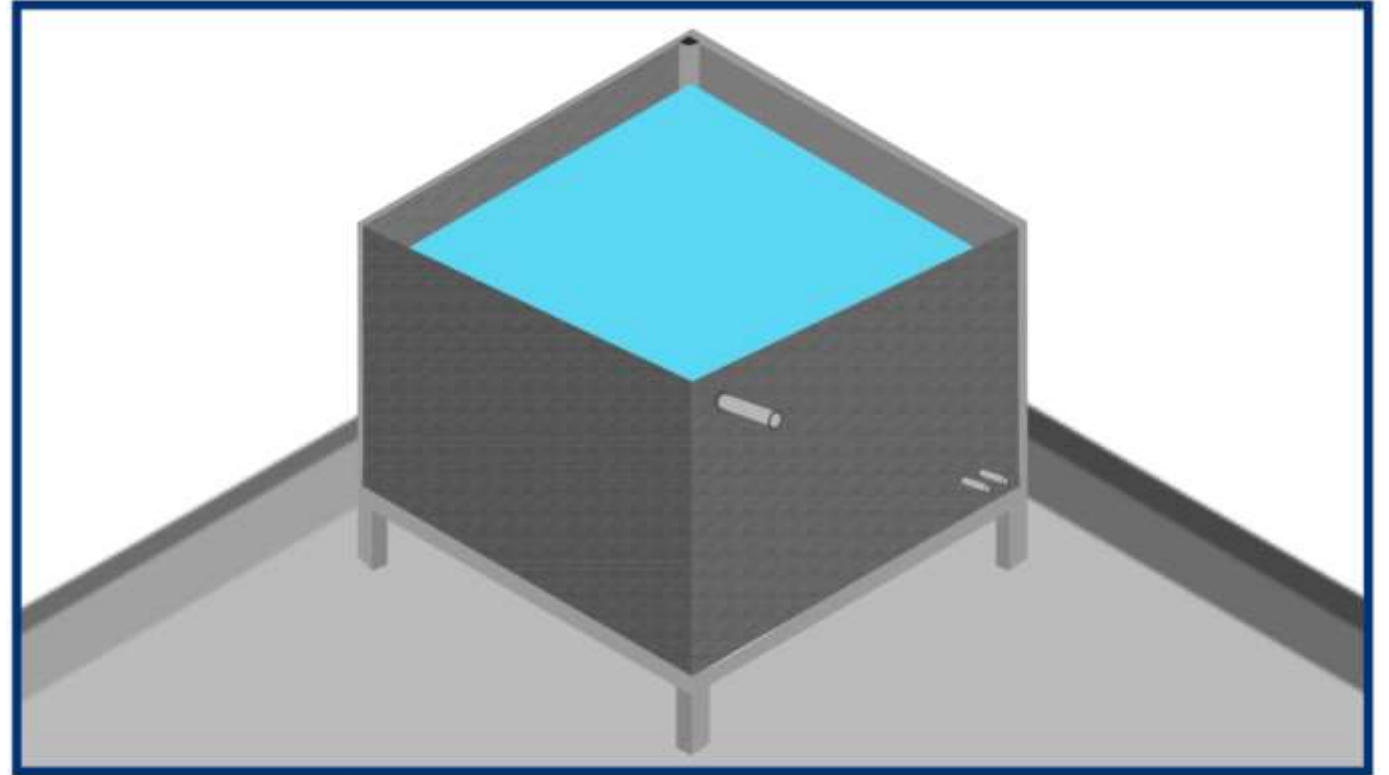



## Step 5

Internal and external plastering with the addition of **Ressi SBR 5850** and **Silmix** in the plaster mix.

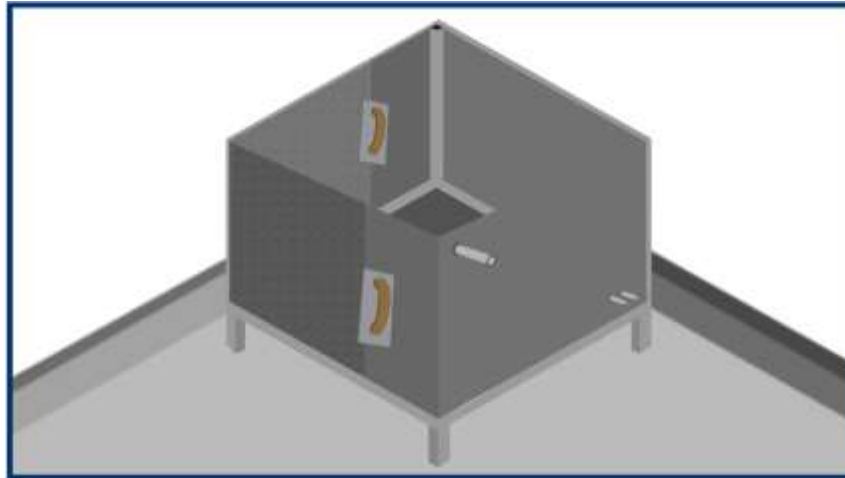
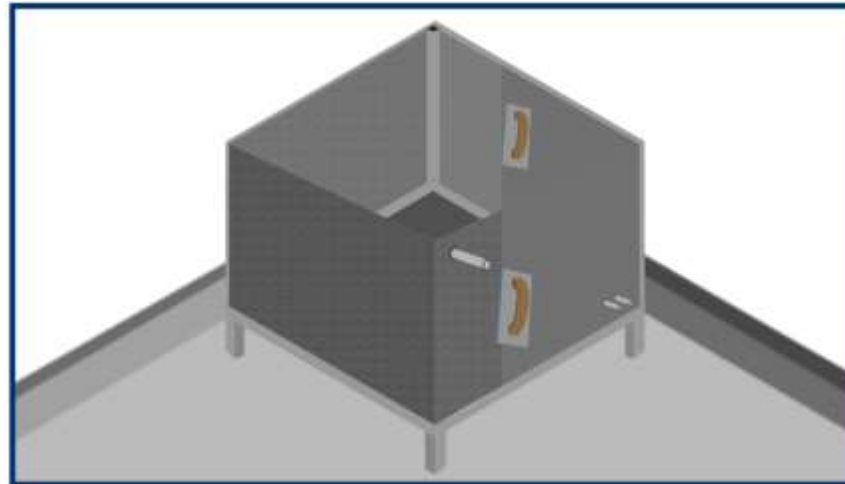

## Step 6

Internal Coating of Zepoxy 400 (Chemical Resistant coating) over the internal plastered surface.

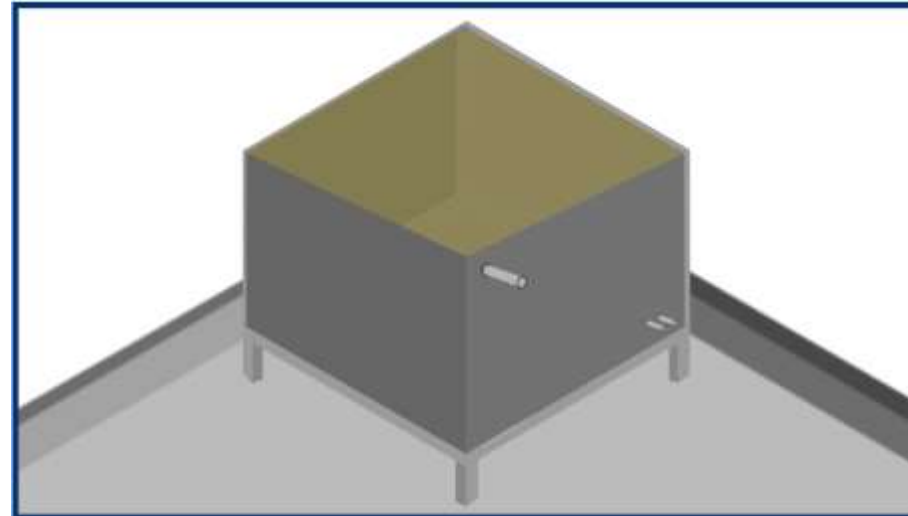
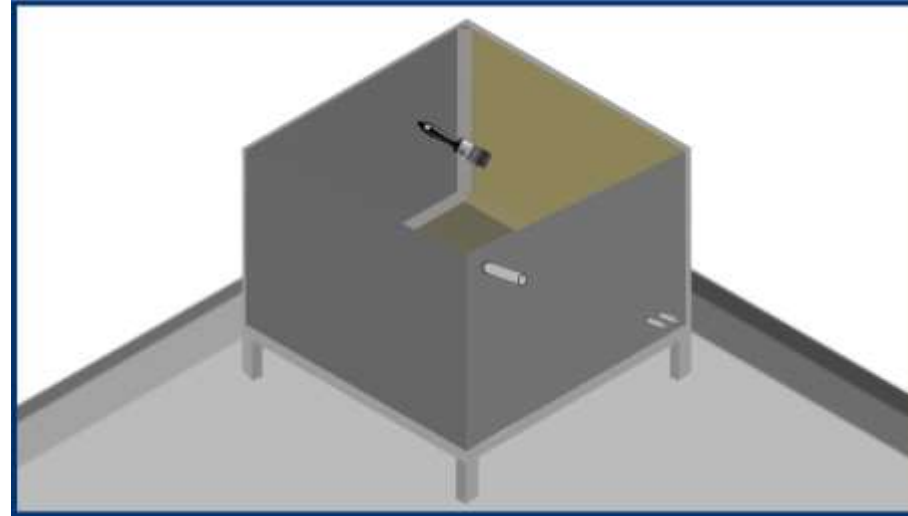

  
**Zepoxy 400**  
High Strength two component  
chemical resistant epoxy coating



# A Durable solution for chemical storage tanks



Thank You

**Where To Find Us**

D-83, S.I.T.E., Industrial  
Area, Manghopir Road, Karachi -  
75530, Pakistan.

**Mobile:** +92 309 7772464

**Tel:** +92-21-32593800-02

**Fax:** +92-21-32593803

**Email:** [info@ressichem.com](mailto:info@ressichem.com)

**Website:** [www.ressichem.com](http://www.ressichem.com)

